

0.5 – 4.0 GHz Broadband Low Noise Amplifier

Features

- ◆ Frequency Range: 0.5 – 4.0 GHz
- ◆ Better than 2.0dB Noise Figure
- ◆ 14 dB Nominal Gain
- ◆ 20dBm Nominal P1dB @ 4V operation
- ◆ Input Return Loss > 10 dB
- ◆ Output Return Loss > 12 dB
- ◆ Single supply operation
- ◆ Nominal Bias : 3V@ 90mA
- ◆ 0.15 μ m InGaAs pHEMT Technology
- ◆ Chip Size : 0.9 mm x 1.1 mm x 0.1 mm

Functional Diagram

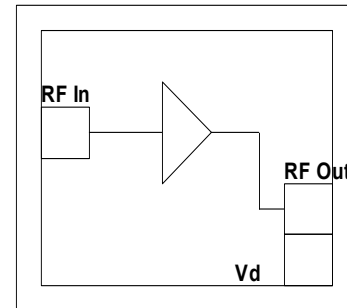

Typical Applications

- ◆ Cellular system
- ◆ Base stations
- ◆ Narrow Band Applications from 800MHz to 3GHz
- ◆ Communication receivers and transmitters.

Description

The ASL1001 broadband MMIC LNA operates from 0.5 – 4.0GHz. The MMIC employs a single stage self-biased amplifier design featuring 50 Ohm input/output impedance. The RF input and output are DC coupled to facilitate low frequency operation. The amplifier operates on a single +3V supply. The Amplifier can also be operated at 2V for lower current operation and at 4V for a higher power output requirement. The LNA features midband input/output return loss of 14dB and a nominal P1dB of 17dBm. In addition to being used as the first stage, the LNA's excellent linearity encourages its usage in the succeeding stages of a receiver chain. The die is fabricated using a reliable Low noise 0.15 μ m InGaAs pHEMT process. The circuit grounds are provided through vias to the backside metallization.

Absolute Maximum Ratings ⁽¹⁾

Parameter	Absolute Maximum	Units
Positive DC Supply	6	V
RF Input Power	20	dBm
Supply current	175	mA
Operating Temperature	-55 to +85	°C
Storage Temperature	-65 to +150	°C

1. Operation beyond these limits may cause permanent damage to the component

Electrical Specifications ⁽¹⁾ @ T_A = 25 °C, V_d = +3V, Z_o = 50 Ω

Parameter	Min.	Typ.	Max.	Units
Frequency	0.5	-	4.0	GHz
Gain	-	16	-	dB
Gain Flatness	-	±1.75	-	dB
Noise Figure	-	1.6	-	dB
Input Return Loss	10	12	-	dB
Output Return Loss	10	12	-	dB
Output Power (P1dB)	16	17	-	dBm
Output Third Order Intercept(IP3)	-	25	-	dBm
Supply Current	75	90	105	mA

Note:

1. Electrical specifications as measured in test fixture.

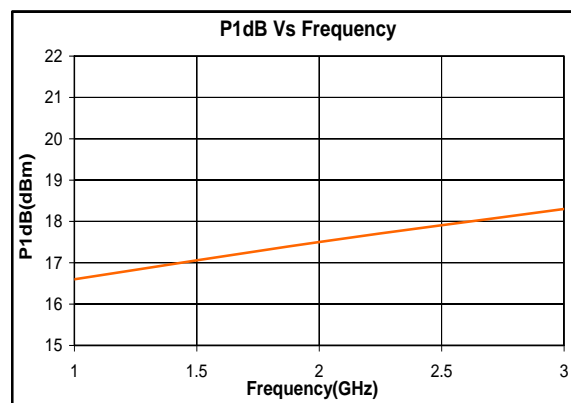
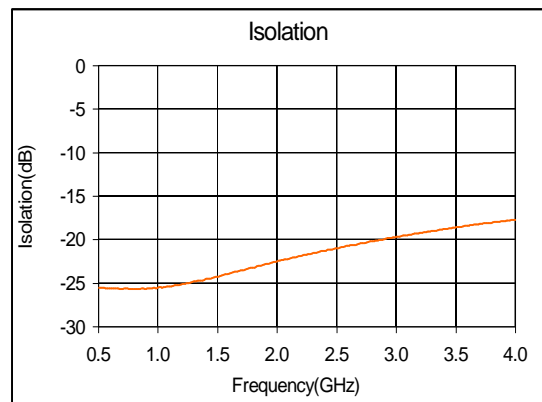
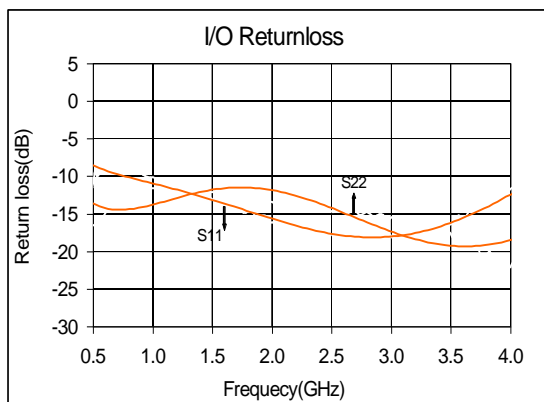
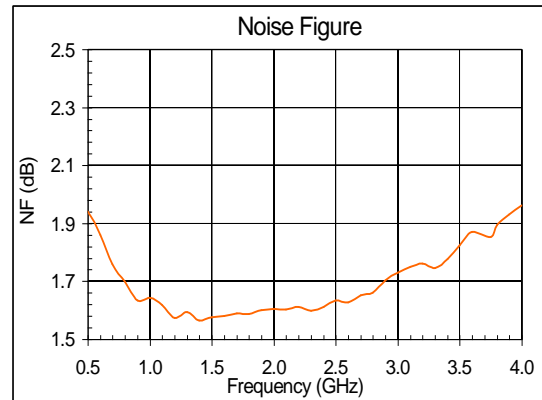
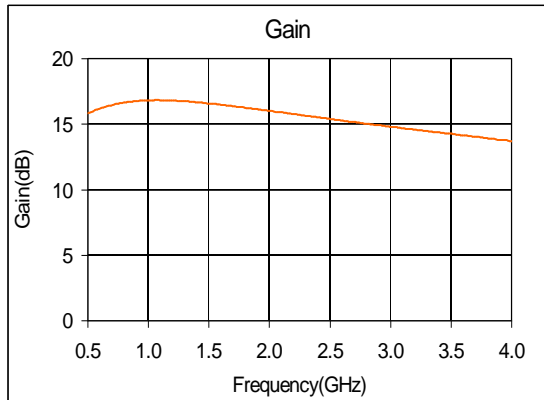
Test fixture data
 $V_d = 3V$, Total Current = 90mA, $T_A = 25^\circ C$

Test fixture data

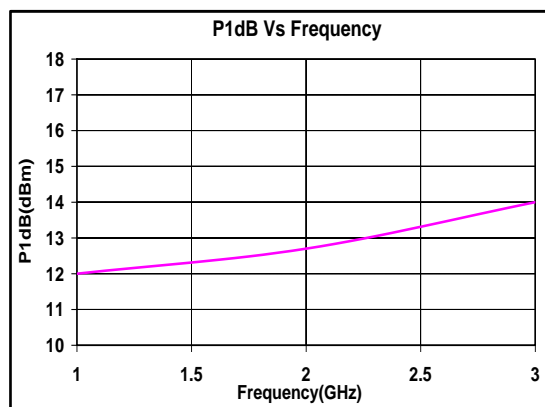
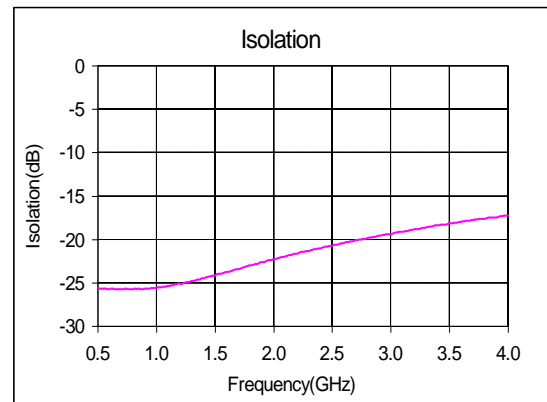
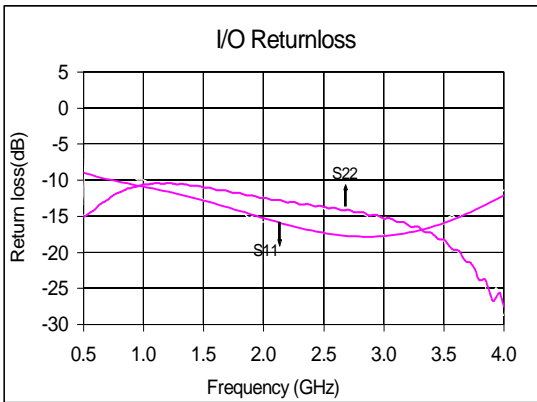
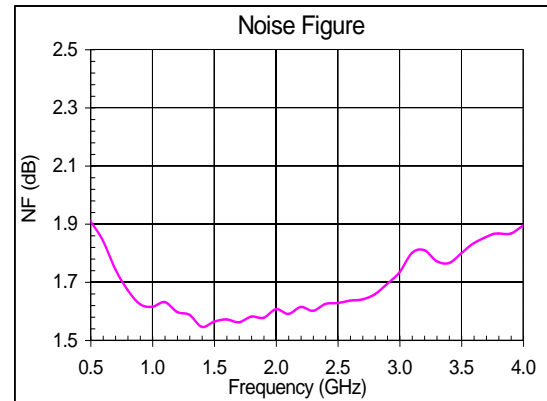
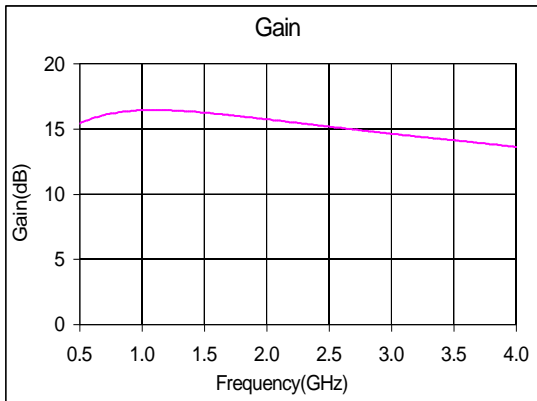
 Vd= 2V, Total Current = 80 mA, T_A = 25 °C

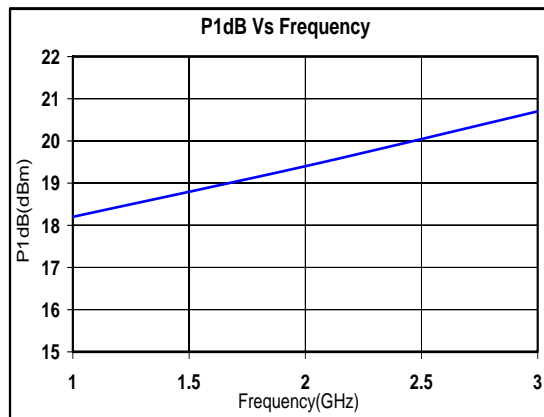
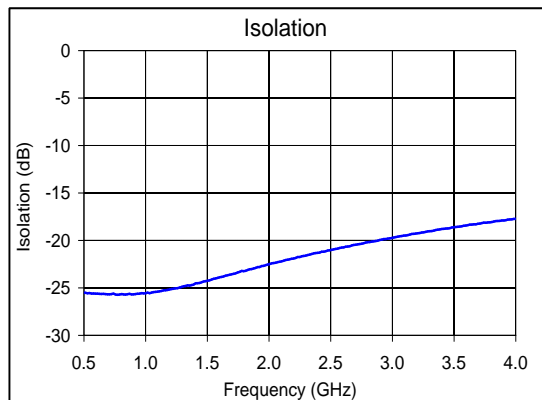
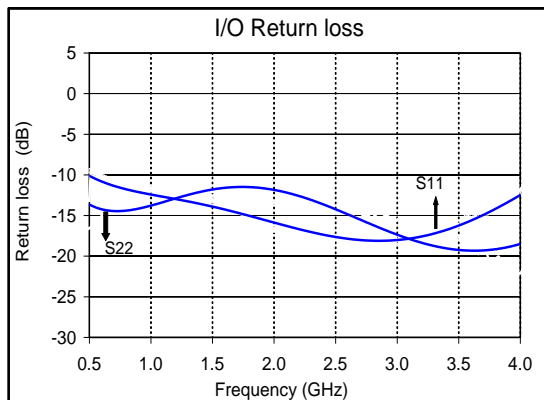
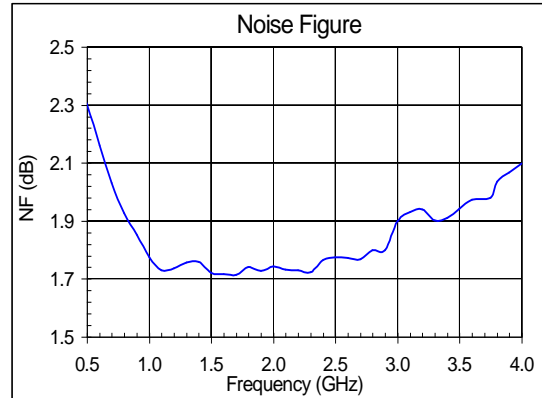
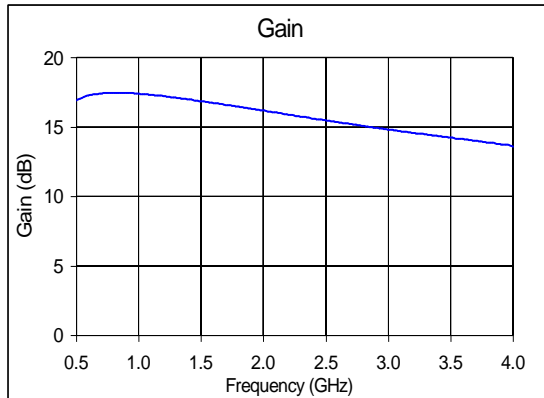
Test fixture data
 $V_d = 4V$, Total Current = 100 mA, $T_A = 25^\circ C$

Mechanical Characteristics

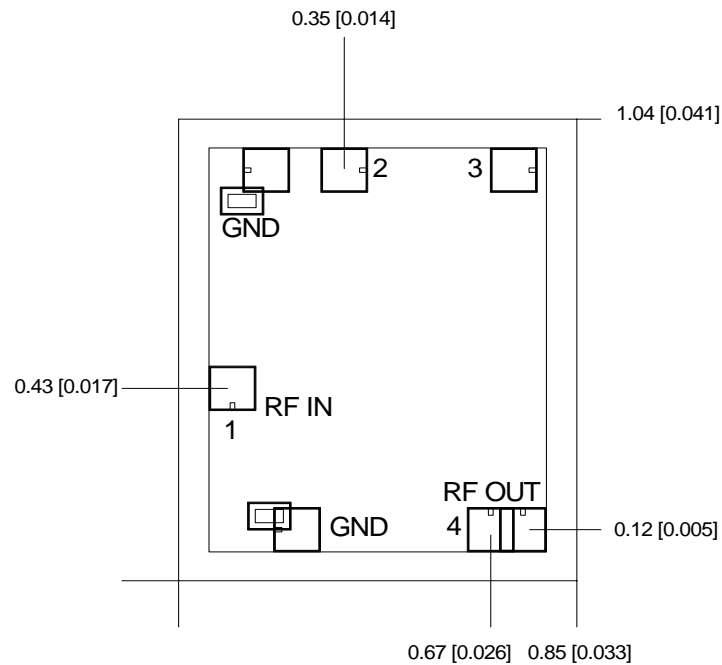

Units: millimeters (inches)

Note:

1. All RF and DC bond pads are 100 μ m x 100 μ m
2. Pad no. 1 : RF In
3. Pad no. 2 : Source bypass
4. Pad no. 4 : RF Out and Vd

Recommended Assembly Diagram

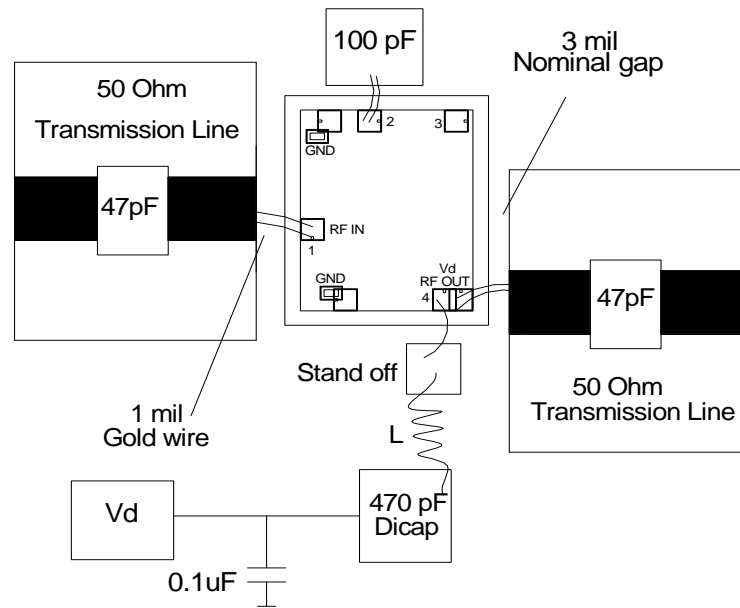

Note:

1. Two one mil (0.0254mm) bond wires of minimum length should be used for RF input, Output and from chip bond pad to 100pF source bypass capacitor.
2. The value of L (RF Choke) is $\sim 68\text{nH}$; an air core inductor should preferably be used for operation beyond 2GHz.
3. All capacitors shown in the assembly diagram (except 0.1 μF) are single layer capacitors.
4. The use of Multilayer capacitors and chip inductors with smaller footprint (0402) is suggested only for frequencies < 2.0 GHz.
5. 0.1 μF capacitor may be additionally used as second level of bypass for reliable operation.

Die attach: For Epoxy attachment, use of a two-component conductive epoxy is recommended. An epoxy fillet should be visible around the total die periphery. If Eutectic attachment is preferred, use of fluxless AuSn (80/20) 1-2 mil thick preform solder is recommended. Use of AuGe preform should be strictly avoided.

Wire bonding: For DC pad connections use either ball or wedge bonds. For best RF performance, use of 150 - 200 μm length of wedge bonds is advised. Single Ball bonds of 250-300 μm though acceptable, may cause a deviation in RF performance.



GaAs MMIC devices are susceptible to Electrostatic discharge. Proper precautions should be observed during handling, assembly & testing

All information and Specifications are subject to change without prior notice